

EXHIBITOR MAGAZINE PRESENTS

# **EXHIBITOR***LIVE*

THE PROFESSIONAL DEVELOPMENT CONFERENCE FOR  
TRADE SHOW AND CORPORATE EVENT MARKETING

CONFERENCE: FEBRUARY 24 – 28, 2019 | EXHIBITION: FEBRUARY 25 – 27, 2019 | MANDALAY BAY CONVENTION CENTER, LAS VEGAS

---

- **Application and Contract  
for Exhibit Space**
- **Product/Service Categories**
- **Terms & Conditions**
- **Display Construction Guidelines**
- **Rules & Regulations**
- **Fire Marshal Regulations**
- **ADA Exhibitor Compliance**

The undersigned (hereinafter, called the "Exhibitor") hereby applies for space in EXHIBITORLIVE produced by Exhibitor Media Group, scheduled to be held at the Mandalay Bay Convention Center, Las Vegas. Conference dates: February 24-28, 2019; Exhibit hall dates: February 25-27, 2019.

Please submit your company name as you would like it to appear in the website, credentials, and Official Show Directory. Only contracted companies in good standing who submit their Directory Listing prior to December 3, 2018 will receive a listing in the Official Show Directory.

1. FIRM NAME: \_\_\_\_\_  
 EXHIBIT CONTACT: \_\_\_\_\_ TITLE: \_\_\_\_\_  
 PROMOTION CONTACT: \_\_\_\_\_ TITLE: \_\_\_\_\_  
 ADDRESS: \_\_\_\_\_  
 CITY: \_\_\_\_\_ STATE: \_\_\_\_\_ ZIP: \_\_\_\_\_  
 COUNTRY: \_\_\_\_\_ PHONE: \_\_\_\_\_ COMPANY TWITTER HANDLE: \_\_\_\_\_  
 EMAIL: \_\_\_\_\_ INTERNET WEBSITE: \_\_\_\_\_  
 FIRM'S FEDERAL TAX ID OR LLC TAX NUMBER: \_\_\_\_\_ (USED FOR COMPANY VERIFICATION PURPOSES)

**2. LOCATION PREFERENCES:** Please indicate your preference for location and configuration of exhibit space as shown on the floor plan at ExhibitorLive.com/ExhibitNow. EXHIBITORLIVE, in its sole discretion, reserves the right to allocate alternate space to the Exhibitor if exhibit space preferences are not available.

Space Usage and Allocation: Booth sharing, piggy-backing of complementary companies or any other form of subletting of space is prohibited (see paragraph B & C). All companies represented on the Show floor must be separately contracted for their own exhibit space. Violators reserving large spaces to accommodate such situations will be subject to re-assignment of space location.

1ST CHOICE: \_\_\_\_\_ 2ND CHOICE: \_\_\_\_\_ 3RD CHOICE: \_\_\_\_\_ 4TH CHOICE: \_\_\_\_\_  
 TOTAL SQ. FT. REQUIRED: \_\_\_\_\_ CONFIGURATION:  ISLAND (MIN. 400 SQ. FT.)  PERIMETER  INLINE  CORNER (ADDITIONAL \$250.00 EACH) HEIGHT REQUIRED: \_\_\_\_\_

**3. PAYMENT TERMS AND SCHEDULE:** Applicant agrees to pay \$42.00 per sq. ft. in U.S. funds. 25% of the total booth fee is due April 13, 2018 with application, 50% of the total exhibit fee is due July 13, 2018 and the remaining balance is due November 1, 2018. Applications received after November 1, 2018 require full payment of total booth fee. There is an additional \$250.00 charge for each open corner where noted, islands excepted.

**4. EXHIBITORLIVE** will make every effort to avoid conflicting space assignments with competitors where known conflicts exist. However, due to the nature of the exhibits, conflicts may be unavoidable. If possible, please try to avoid placing our booth near the following companies:

\_\_\_\_\_

**5. PRODUCTS/SERVICES TO BE EXHIBITED:** To aid in assigning exhibit space and to determine eligibility to exhibit, please describe the product or service to be exhibited. Exhibits must pertain to the planning or production of a corporate exhibit program and/or corporate events.

\_\_\_\_\_

The Corporation further reserves the right in its sole discretion, to limit the types of companies and products represented at its trade show, to accept or reject applications, and to assign booth space as it deems appropriate.

**6.** This contract shall not be binding unless and until it is accepted and approved in writing by EXHIBITORLIVE by the signature of its duly authorized representative. An electronic confirmation of the exhibitor's assigned exhibit space constitutes acceptance of the contract by EXHIBITORLIVE. The Exhibitor and the Managing Directors agree to be bound by rules set forth, including those in this Application & Contract for Exhibit Space, the Terms & Conditions, the Display Construction Guidelines, the Rules and Regulations, the Mandalay Bay Fire Marshal Regulations, Exhibitor Guide and Services Manual, and in any correspondence outlining revised booth location, or other notices, etc., all of which are incorporated herein and made a part of this contract. In witness whereof, applicant has caused this contract to be signed by an officer of the company or person duly authorized. I understand that by providing the email address and/or fax number(s) above, on behalf of the company/organization specified above, I am authorized to and hereby consent for the company/organization to receive EXHIBITORLIVE related faxes and emails from Exhibitor Media Group, Hall-Erickson Inc., and the officially designated contractors, venues, or other companies the managing directors have officially appointed to provide services for EXHIBITORLIVE.

SIGNATURE: \_\_\_\_\_ DATE: \_\_\_\_\_

NAME (PRINT): \_\_\_\_\_

NAME: \_\_\_\_\_ SIGNATURE: \_\_\_\_\_

**If full payment is not received by due dates outlined in this contract, your signature authorizes EXHIBITORLIVE to charge the payments to your credit card on file.**

**If paying by check, mail Application, Product/Service Category Form AND PAYMENT to:**  
 EXHIBITORLIVE  
 Dept. 20-7040, PO Box 5997  
 Carol Stream, IL 60197-5997

**Expedite Address:**  
 EXHIBITORLIVE- c/o Hall-Erickson Inc.  
 98 E. Chicago Ave., Ste. 201  
 Westmont, IL 60559  
 P: 630-434-7779  
 F: 630.434.1216  
 email: EXHIBITORLIVE@heexpo.com

(FOR OFFICE USE ONLY)		F
Sq. ft. required: _____	Assigned: _____	
Appl. Rec'd: _____		
Accepted by EXHIBITORLIVE on: _____		
by: _____		
(for Hall-Erickson Inc.)		

COMPANY NAME: \_\_\_\_\_

Rank your primary offerings (starting at 1 and up to as many as 5, if applicable) of those products or services your company provides to the exhibit and corporate event marketing industry on an exclusive basis. This product/service listing, including all exhibitors in good standing who complete this form, will appear on the EXHIBITORLIVE website.

**EXHIBITS & DISPLAY PRODUCERS**

- Exhibit Producers
- Designers
- Fabric Architecture
- International
- Mobile Marketing Manufacturers
- Rental

- E-Literature
- Event Audits
- Event Design & Production
- Event Management
- Event Marketing
- Exhibit Components
- Exhibit Program Management
- Exhibit Storage
- Exhibition Contractors
- Fabric Draping
- Fabrics
- Fasteners
- Fiber Optics
- Flooring
- Food Service Equipment
- Frames and Displays
- Furniture
- Graphic Design
- Graphics - Grand Format
- Graphics - Large Format
- Graphics - Lenticular
- Hanging Signs
- Holographics
- Housing and Accommodations
- Inflatables
- Installation and Dismantle
- Insurance
- Interactive Multimedia
- Internet/Wireless Services
- Kiosks
- Language Translation
- Lead Management
- Lead Retrieval
- LED Panels
- Light Boxes
- Lighting
- Lighting Design
- Lighting Products
- Literature Displays
- Live Presentations
- Magicians
- Mannequins/Museum Figures
- Marketing Agency
- Massage
- Measurement
- Mobile Applications
- Models/Props
- Multimedia
- Multi-Story Exhibits
- Outdoor Displays and Signs
- Photography

- Plants
- Power Cords/Cables
- Printing Services
- Product Pedestal
- Professional Certification
- Promotional Products
- Public Relations
- Publications
- Recruiters
- Registration
- Research
- RFID Technology
- Road Shows
- Security
- Shipping & Transportation
- Shipping Supplies
- Signage
- Social Media Marketing
- Software/Applications
- Special Effects
- Staffing
- Sweepstakes/Games/Contests
- Tablet Computer Rental
- Talent/Entertainment/Speakers
- Telemarketing
- Traffic Builders
- Training Programs/Seminars
- Transportation
- Truss/Spaceframes
- Turntables
- Used Exhibits
- VAT Recovery
- Venues
- Video Production
- Virtual Events
- Virtual Reality
- Waterwalls
- Web Marketing

- CAD Detailing Software
- CAD Engineering and Detailing
- Carpet
- Cases
- Core Materials
- Crates
- Custom Engineering
- Display Fixtures
- Exhibit Components
- Exhibit Fabrication
- Fabric Draping
- Fabrics
- Fasteners
- Flame Retardant Solutions
- Flooring
- Food Service Equipment
- Furniture
- Graphics - Grand Format
- Graphics - Large Format
- Graphics - Lenticular
- Ink
- Installation and Dismantle
- Laminates
- Lighting
- Lighting Design
- Lighting Products
- Literature Displays
- Models/Props
- Multi-Story Exhibits
- Panel Clip Connectors
- Panels
- Photography
- Plants
- Power Cords/Cables
- Printers
- Printing Services
- Signage
- Special Effects
- Standoffs
- Substrates
- Truss/Spaceframes
- Turntables
- Used Exhibits
- Waterwalls

**PORTABLE DISPLAY SYSTEMS**

- Modular Exhibit Systems
- Banner Displays
- In-line Systems
- Pop-up
- Tabletop

**TRADE SHOW PRODUCTS/SERVICES**

- 3D Photographic Printing
- 3D Product Demonstrations
- Associations
- Attendance Tracking
- Audience Response Systems
- Audiovisual - Staging
- Audiovisual Display Stands
- Audiovisual Equipment
- Audiovisual Production
- Augmented Reality
- Backdrops
- Badges
- Bags
- Banners
- Caricatures
- Carpets
- Cases
- Catering
- Celebrities
- Charging Stations
- Computer Rental
- Contest Insurance
- Convention & Visitors Bureau
- Coolers and Refrigerators
- Costumes
- Counters
- Crates
- Custom Apparel
- Customs and Export Services
- Decals
- Destination Management
- Digital Signage
- Direct Marketing
- Display Fixtures
- DVD/CD's

**SUPPLIER TO SUPPLIER**

- Acrylics
- Adhesive-Coated Products
- Aluminum Extrusion
- Architectural Curtains and Chains
- Associations
- Audiovisual - Staging
- Audiovisual Equipment
- Backdrops
- Box Frame Panels
- Cable Display Systems
- Cable Protectors

**INTERNATIONAL**

- We provide International Services

**GREEN PRODUCTS**

- Green Products will be displayed at the show.

Send completed "Application" and "Product/Service Categories" to Hall-Erickson, Inc.: 630-434-1216, EXHIBITORLIVE@heexpo.com or mail with "Application" and payment (if required) to address on bottom of "Application."

Upon acceptance of the contract, the Exhibitor shall be bound by the rules and regulations set forth herein and by such amendments or additional rules and regulations, which may be established by EXHIBITORLIVE. References to EXHIBITORLIVE herein shall be deemed to include the producer, the advisory committees, and the managing directors of the trade show and any duly authorized representative, agent or employee of the foregoing.

**A. Eligibility to Exhibit** – All manufacturers or suppliers of a product or service used in the planning or production of a corporate exhibit program and/or corporate events. All Exhibitors must be legal entities and in good standing with EXHIBITOR Shows and Exhibitor Media Group. Contracted Exhibitors only are permitted to rent meeting rooms on a space-available basis.

**B. Products and Services to be Exhibited** – No Exhibitor shall exhibit, or permit to be exhibited in the space allotted to him any goods or services other than those specified on the application when approved by EXHIBITORLIVE, nor shall the Exhibitor permit to be exhibited therein, displays, literature or advertising of any sort bearing any name or form of advertisement other than his own. Retail sales are not permitted except by separate contractual agreement.

**C. Space Usage and Allocation** – The space applied for is to be used solely for the Exhibitor whose name appears on the application, and it is agreed that the applicant will not assign, sublet, or apportion the whole or any part of the space or meeting room allotted. Exhibitor may not exhibit, offer for sale, give as premium, or advertise articles not manufactured or sold in their name, except where such articles are required for the proper demonstration or operation of Exhibitor's display, in which case identification of such articles shall be limited to the regular nameplate, imprint, or other identification which in standard practice appears normally on them. Exhibitor may not permit these non-exhibiting companies' representatives in their booth. Rulings of the Managing Directors shall in all instances be final with regard to use of any exhibit space. Furthermore, the Exhibitor agrees that the Managing Director has sole authority over the assignment of exhibit space and may be required to change the Exhibitors confirmed exhibit space in order to accommodate the needs of the show. In the event the Exhibitor's booth number is changed, the Managing Director will notify the exhibitor.

**D. Payment and Cancellation/Reduction of Exhibit Space** – Applicant agrees to pay \$42.00 per sq. ft. in U.S. funds. An additional \$250.00 charge will be added for each open corner, islands excepted. Upon acceptance of this application by EXHIBITORLIVE, it shall be a legally binding contract between the Exhibitor and EXHIBITORLIVE. Refunds will not be issued under any circumstances, regardless of the date of cancellation or reduction of exhibit space, unless EXHIBITORLIVE cancels the contract or reduces the Exhibitor's exhibit space, for reasons other than non-payment by the Exhibitor. EXHIBITORLIVE will be entitled to retain or collect 100% of the Exhibitor's total contract obligation if the Exhibitor cancels or reduces their exhibit space. The acceptance by EXHIBITORLIVE or the Managing Director of a deposit with an application does not in any way constitute acceptance of the application or a grant of permission to exhibit. If an application is denied, a full refund of the deposit will be made promptly. The applicant agrees that in the event space of greater square footage is selected, assigned or allotted to it at its request or with its consent, it will pay the additional amount required promptly upon receipt of notice to that effect; and, if space of less square footage

is assigned, it will accept a refund based upon the reduced square footage, provided show management is advised of the request to reduce space prior to November 1, 2018. Exhibitors requesting an increase or reduction in square footage are subject to booth relocation. Failure to make payments when due or pay the balance due on or before November 1, 2018 can result in the reassignment of your booth location or cancellation of the contract.

**E. Standard Booth Equipment** – Includes a drape 8' high along the back line with side rails 33" high and 7" x 44" I.D. sign showing firm name. Width of all spaces shown on the official floor plan is from center of side rails and depth is overall measurement from face of the front post to back of rear post. All contracted exhibit space is required to have carpeting or other flooring supplied by the Exhibitor.

**F. Rules & Regulations and Display Construction Guidelines** – Exhibitors agree to abide by and conform to the Display Construction Guidelines and Rules and Regulations set forth by EXHIBITORLIVE. The Exhibitor acknowledges these rules and guidelines are hereby made part of this exhibit space contract.

**G. Multi-Story Exhibit Regulations** – Exhibitors agree to abide by and conform to the Multi-Story Exhibit Construction Guidelines.

**H. Contests, Promotions, Models and Literature Distribution** – Exhibitors agree to abide by and conform to the applicable Rules & Regulations outlined.

**I. Fire Regulations** – Exhibitors agree to abide and conform to the Mandalay Bay Fire Marshal Regulations set forth by EXHIBITORLIVE. The Exhibitor acknowledges these Fire Regulations are hereby made part of this exhibit space contract.

**J. Installation of Exhibits** – Installation of exhibits may begin on Friday, February 22, 2019. Crates must be removed and installation complete by 4:30 PM Sunday, February 24, 2019. No freight will be accepted after 12 Noon Sunday, February 24, 2019. All shipments must be prepaid.

**K. Dismantling of Exhibits** – Dismantling of exhibits may begin at 3:30 PM, Wed., February 22, 2019 and must be completed by Thursday, February 28, 2019. No Exhibitor shall have the right prior to the closing of the Show to pack or remove articles on exhibit without the permission and approval in writing of EXHIBITORLIVE. The Exhibitor agrees that EXHIBITORLIVE and the Managing Director shall, without incurring any liability for damage or loss, have the right to dismantle and pack any property of any Exhibitor who has failed to do so in the time allotted, or to order such work done at the sole expense of the Exhibitor. The Exhibitor further agrees that the Managing Director, at its sole discretion, shall have the right and authority to clear from the premises any exhibit material or other property of the Exhibitor for which sufficient shipping arrangements have not been made, to designate carriers for its return, to send it to public or private storage, or to otherwise dispose

of it, without incurring any liability therefore, and all costs of such removal, return, storage and other disposition shall be charged to and promptly paid by the Exhibitor.

**L. Badges and Exhibit Personnel** – Admission will be by Exhibitor badge only. Identification badges are not transferable. The Exhibitor shall have an authorized representative present at the Show throughout all exhibit periods and during the installation and dismantling of his exhibit. The name of the authorized representative shall be furnished to EXHIBITORLIVE not less than (60) sixty days before the opening date of the Show. Exhibitors may forfeit participation in future EXHIBITOR Shows if Exhibitor badges are transferred or ordered for attendees or customers not scheduled to work in the Exhibitor's booth.

**M. Union Labor and Work Agreements** – The Exhibitor hereby agrees to abide by all agreements made between the unions, EXHIBITORLIVE, its agents and Mandalay Bay pertaining to the use of union labor while in Mandalay Bay.

**N. Use of an Exhibitor Appointed Contractor (EAC)** – The Exhibitor hereby agrees not to contract for, nor to use, any services in connection with its exhibit in the Mandalay Bay Convention Center except such as shall be made available or approved by the Managing Directors not less than 30 days before the opening date of the Show. The Exhibitor shall supply to the Managing Directors the names of any persons or organizations other than those designated as Official Contractors in the Exhibitor Guide & Service Manual, who are proposed for the performance of any service for the Exhibitor. The Managing Directors will promptly notify Exhibitor of its approval or disapproval of such selections. Use of any non-official service contractor is also subject to those designated contractors providing proof of insurance to the Managing Directors 30 days prior to the opening of the Show. The certificate should name EXHIBITORLIVE, the producers, Exhibitor Media Group, the Managing Directors, Hall-Erickson, Inc. (hei), the General Contractor, Freeman and the Mandalay Bay Resort & Casino as additional insureds. EAC's include installation and dismantling contractors, florists, photographers, furniture and carpet suppliers and any other supplier or contractor used by the Exhibitor that is not the Show's official contractor. Certain services are considered exclusive contractors of Mandalay Bay and Exhibitors are required to use their service for: Booth Catering, Booth Cleaning, Electrical, Internet, Plumbing, Rigging, Telephones, Video Signal Distribution.

**O. Direct Sales** – EXHIBITORLIVE is for educational and informational purposes. No retail sales are allowed within the exhibit area at any time, except by separate contractual agreement, but orders may be taken for future delivery.

**P. Social Functions/Suitcasing/Outboarding** – Contracted Exhibitors may conduct social functions in public areas of Mandalay Bay, which do not conflict with scheduled programs or activities of EXHIBITORLIVE. No Exhibitor shall conduct or sponsor during published Show or Seminar hours any banquet, breakfast, luncheon, party

or other function for attendees, or for those who have been invited to attend EXHIBITORLIVE, without the written approval of EXHIBITORLIVE. EXHIBITORLIVE has a suitcasing and outboarding policy whereby Exhibitors and non-Exhibitors who solicit in the aisles, or anywhere else on the property outside the exhibit hall, or support any event within the venue that is hosted by a non-exhibiting supplier, may be subject to penalties that include cancellation/closure of their exhibit space from EXHIBITORLIVE without refund, loss of space selection priority points and may have their application for space denied for two (2) years from the year of the infraction. Non-Exhibitors will be asked to leave EXHIBITORLIVE, without refund of any monies paid, and will not be allowed to attend the event for two (2) years from the year of the infraction.

**Q. Age Limitation** – Due to insurance liabilities no child 17 years of age or under will be permitted on the Show floor at any time regardless of affiliation or circumstances. This rule applies to Exhibitors as well as attendees.

**R. Liability and Security** – Exhibitor assumes responsibility and agrees to indemnify and defend EXHIBITORLIVE, the Managing Directors, Mandalay Bay Resort & Casino, Mandalay Resort Group, and their respective subsidiaries and affiliates, owners, shareholders, directors, officers, employees, agents, representatives and successors from any claims or expenses arising out of the use of the exhibition premises. EXHIBITORLIVE, the Managing Directors and the Mandalay Bay Resort & Casino shall not be liable for, and are hereby released from, any claims, liabilities, losses, damages, costs or expenses relating to or arising out of any injury to any personnel of Exhibitor or to any other person or any loss of or damage to any property of Exhibitor or any other property where such injury, loss or damage is incident to, arises out of, or is in any way connected with Exhibitor's participation in EXHIBITORLIVE, and the Exhibitor shall be responsible for any such injury, loss or damage, or any expenses relating thereto, and the Exhibitor hereby agrees to protect, indemnify, hold harmless and defend EXHIBITORLIVE, the Managing Directors, Mandalay Bay Resort & Casino and their respective owners, shareholders, directors, officers, employees, agents, representatives and successors, subsidiaries, affiliates, against all such claims, liabilities, losses, damages, costs and expenses, including reasonable attorney's fees and costs of litigation; provided that the foregoing shall not apply to injury, loss or damage caused by or resulting from the sole negligence of EXHIBITORLIVE, the Managing Directors, Mandalay Bay Resort & Casino, and their respective subsidiaries, affiliates, shareholders owners, directors, officers, employees, agents or representatives. In addition to the foregoing, the Exhibitor agrees that it will make no claim of any kind against EXHIBITORLIVE, the Managing Directors, Mandalay Bay Resort & Casino and their respective owners, subsidiaries, affiliates, shareholders, directors, officers, employees, agents, representatives or successors for any injury, loss, cost or damage of any nature or character whatsoever, including, without limiting the foregoing, any claim for damage to the Exhibitor's business by reason of the failure to hold the Show or to provide space for any exhibit or the removal of the exhibit, or for any action of EXHIBITORLIVE, the Managing Directors,

Mandalay Bay Resort & Casino and their respective subsidiaries, affiliates, shareholders, owners, directors, officers, employees, agents or representatives in relation to the exhibit, the Exhibitor or the Show.

**S. Cancellation of the Exposition** – Should any contingency interrupt or prevent the holding of EXHIBITORLIVE, EXHIBITORLIVE will return such portion of the amount paid for space as may be determined to be equitable by EXHIBITORLIVE after deduction of such amounts as may be necessary to cover expenses incurred by EXHIBITORLIVE in connection with the Show. If for any reason, EXHIBITORLIVE determines that the location of the Show should be changed or the dates of the Show postponed, no refund will be made but EXHIBITORLIVE shall assign to the Exhibitor, in lieu of the original space, such other space as EXHIBITORLIVE deems appropriate and the Exhibitor agrees to use such space under the same rules and regulations. EXHIBITORLIVE shall not be financially liable or otherwise obligated in the event the Show is canceled, postponed or relocated except as provided herein.

**T. Authority of EXHIBITORLIVE and the Managing Directors** – EXHIBITORLIVE shall have power to adopt and enforce all show attendance rules and regulations with respect to the kind, nature and eligibility of Exhibitors adopted by it or set forth herein. EXHIBITORLIVE has appointed the Managing Directors to act as their duly authorized agent and to enforce all rules and regulations. Their decision on such matters as may be referred to them shall be final.

**U. Live Music, Photographs, Intellectual Property Rights and Other Copyrighted Material** – Each Exhibitor is responsible for obtaining all necessary licenses and permits to use live music, photographs or other copyrighted material in Exhibitor's booth or display. No Exhibitor will be permitted to play, broadcast or have performed any live music or use any other copyrighted material, such as photographs or other artistic works, without first presenting to EXHIBITORLIVE proof satisfactory that the Exhibitor has, or does not need, a license to use such live music or copyrighted material. EXHIBITORLIVE reserves the right to remove from the exhibit hall all or any part of any booth or display which incorporates live music, photographs or other copyrighted or trademarked material and for which the Exhibitor fails to produce proof that the Exhibitor holds all required licenses. The Exhibitor shall remain liable for and shall indemnify and hold EXHIBITORLIVE, their agents and employees, harmless from all loss, cost, claims, causes of action, suits, damages, liability, expenses and costs, including reasonable attorney's fees, arising from or out of any violation or infringement (or claimed violation or infringement) by Exhibitor, Exhibitor's agents or employees of any patent, copyright or trade secret rights or privileges.

**V. Defaults** – If the Exhibitor is in default of payment, access to the Exhibitor Guide & Services Manual, Exhibitor registration, Exhibitor listings, etc., will be denied until the account is brought current. If the Exhibitor is a party to other contracts with the Producer, including but not limited to contracts for exhibit space, advertising space or direct marketing services, and the Exhibitor fails to make any payment when due under

this or any other contract (hereinafter the "Defaulted Contract"), the Producer may, in its sole discretion and without prior notice to the Exhibitor, reapply any or all funds paid by the Exhibitor under any contract with the Producer to the payment due on the Defaulted Contract and, in such event, the Producer shall promptly notify the Exhibitor of such application. In the event that such reapplication shall create default under a contract other than the Defaulted Contract, which default is not cured within 10 days after notice to the Exhibitor, then the Producer may terminate that contract. In such event, all of the provisions set forth under the heading "Cancellation" shall apply. In the event that it shall be necessary for Producer to bring suit to enforce any of its rights hereunder, Producer shall be entitled to recover all costs of such suits, including reasonable attorney's fees.

**W. Insurance** – EXHIBITORLIVE requires that each Exhibitor maintain general public liability insurance against claims for personal injury, death or property damage incident to, arising out of or in any way connected with the Exhibitor's participation in the exhibition, in an amount of not less than one million dollars (\$1,000,000) for personal injury, death or property damage in any one occurrence. Such insurance maintained by the Exhibitor must be issued by an insurance company reasonably acceptable with an A.M. Best rating A- or higher to the Managing Directors and should include coverage of the indemnification obligations of the Exhibitor under these rules and regulations, and shall name EXHIBITORLIVE, the producers, Exhibitor Media Group, the Managing Directors, Hall-Erickson, Inc. (hei), the General Contractor, Freeman and the Mandalay Bay Resort & Casino as additional insureds on the general liability policy. Each Exhibitor is required to indemnify and hold harmless the Mandalay Bay Resort & Casino from all liability (damage or accident) which might ensue from any cause resulting or connected with transportation, placing, removal or display of exhibits. Each Exhibitor is required to carry workers compensation coverage protecting employees in accordance with the laws of the State of Nevada. Each Exhibitor acknowledges that it is responsible for obtaining, for its protection and entirely at its expense, such property insurance for its exhibit and display materials as the Exhibitor deems appropriate. The Exhibitor understands that neither EXHIBITORLIVE, the producers, Exhibitor Media Group, the Managing Directors, Hall-Erickson, Inc. (hei), the General Contractor, Freeman nor the Mandalay Bay Resort & Casino maintain insurance covering the Exhibitor's property and it is the sole responsibility of the Exhibitor to obtain such insurance. Any policy providing such property insurance must contain an express waiver by the Exhibitor's insurance company of any right of subrogation to any claims against EXHIBITORLIVE, the producers, Exhibitor Media Group, the Managing Directors, Hall-Erickson, Inc. (hei), the General Contractor, Freeman Co. and the Mandalay Bay Resort & Casino.

**X. Sound Amplifying, Reproducing Equipment** – Exhibitors agree to the policy set forth in the Rules & Regulations and Display Construction Guidelines.



**In-Line Booth Regulations**  
*One or more 10'x10' booths in a straight line*

Linear booths, also called "in-line" booths are generally arranged in a straight line and have neighboring exhibitors on their immediate right and left, leaving only one side exposed to the aisle. Display materials should be arranged in such a manner so as not to obstruct sight lines of neighboring exhibitors.

**Height**  
 Exhibit fixtures, components and identification signs will be permitted to a maximum height of 8'3" (2.5m).

**Hanging Signs**  
 Hanging signs are prohibited in linear booths.

**Set-Back**  
 All display fixtures over 4'0" (1.22m) in height and placed within 10 lineal feet (3.5m) of an adjoining exhibit must be confined to the rear five feet of the exhibit space to avoid blocking your neighbor's visibility. Exhibitors with larger spaces - 30 lineal feet (9.14m) or more may extend booth fixtures, signage, and other display items all the way to the front line of their exhibit booth; provided that these items are at least 10 lineal feet away from any neighboring booth.

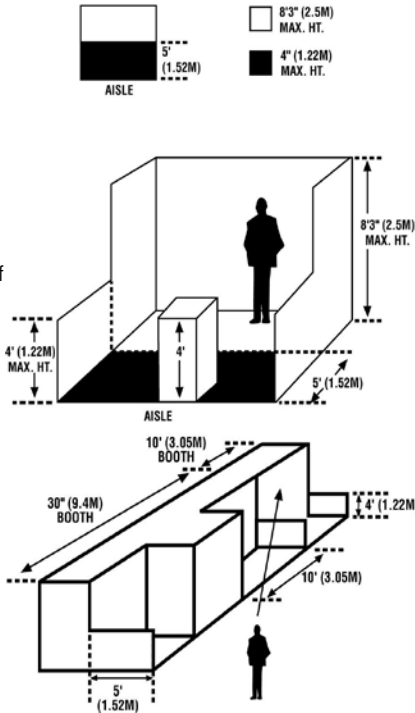

**Extended Header**  
*For use with in-line booth booths*

**Extended Header Booth**  
 An Extended Header Booth is a Linear Booth 20ft (6.10m) or longer with a center extended header.

The rules and restrictions for Linear Booths apply to Extended Header Booths. An extended center header is subject to a maximum height of 8ft (2.38m), a maximum width of 20 percent of the length of the booth in this case, 4ft (1.219M), or 20% of 20ft, and a maximum depth of 1' in height for the horizontal support arms. The vertical panel must be positioned no more than 9ft (2.743m) from the back wall.

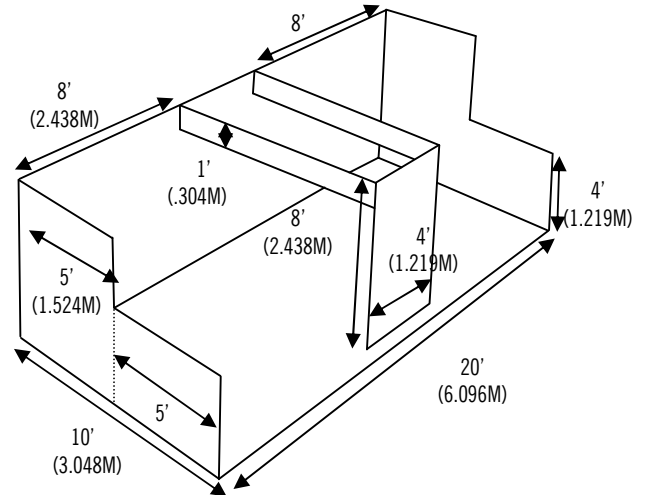

**Canopies and Ceilings**  
*For use with in-line booth booths*

**Canopies and Ceilings**  
 Canopies, including ceilings, umbrellas and canopy frames, can be either decorative or functional (such as to shade computer monitors from ambient light or to allow for hanging products). Canopies for Linear or Perimeter Booths should comply with Line-of-Sight requirements. (See "Use of Space" for Linear or Perimeter Booths).

Company names, logos, text and or graphics are not permitted on the sides of the canopy valance or peak when adjacent to a neighboring booth (solid colors are permitted). Graphics and/or text will be allowed on the outside of the canopy only when booth is positioned on an aisle; or when the canopy wall is separated by at least 10' (ten) from a neighboring exhibitor.

The bottom of the canopy should not be lower than 7ft (2.13m) from the floor within 5ft (1.52m) of any aisle. Canopy supports should be no wider than three inches 3in (0.8m). This applies to any booth configuration that has a sight line restriction, such as a Linear Booth.

Fire and Safety regulations in many facilities strictly govern the use of canopies, ceilings, and other similar coverings. Check with the appropriate local agencies prior to determining specific exhibition rules. Please visit: [clarkcountynv.gov/depts/fire](http://clarkcountynv.gov/depts/fire)

**IMPORTANT**  
 Exhibitors are cautioned when installing a display with a ceiling to check with the local fire department to insure that their display meets with the necessary fire safety precautions involving smoke alarms, fire extinguishers, sprinkler systems, etc.

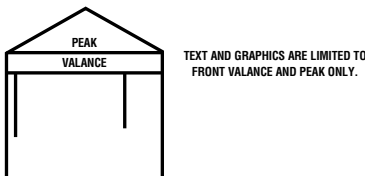
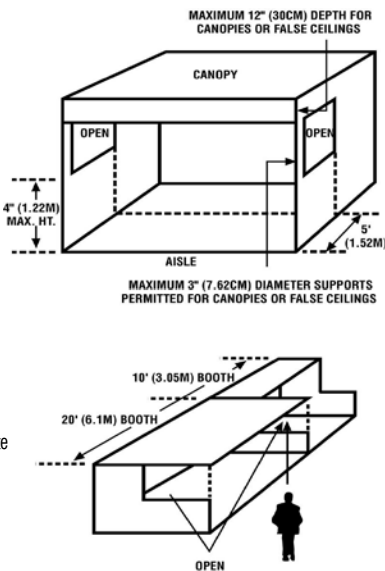

**Perimeter Booth Regulations**  
*One or more 10'x10' booths in a straight line on a perimeter aisle*

A perimeter booth is a linear booth that backs to an outside wall of the exhibit facility rather than to another exhibit.

**Height**  
 Exhibit fixtures, components and identifications signs will be permitted to a maximum height of 16'.

**Intent**  
 Outer perimeter booths do not back up to another exhibitor's booth. Display back walls and materials over 8'3" will not interfere with or distract from any other exhibit booth.

**Hanging Signs**  
 Hanging signs are prohibited in perimeter linear booths.

**Set-Back**  
 All display fixtures over 4'0" (1.22m) in height and placed within 10 lineal feet (3.05m) of an adjoining exhibit must be confined to the rear five feet of the exhibit space to avoid blocking your neighbor's visibility. Exhibitors with larger spaces - 30 lineal feet (9.14m) or more may extend booth fixtures, signage, and other display items all the way to the front line of their exhibit booth; provided that these items are at least 10 lineal feet away from any neighboring booth.

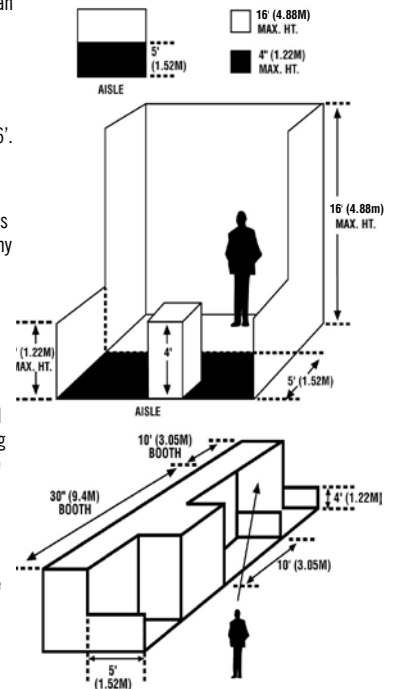

**Island Booth Regulations**

**Exhibit space, 400sf or greater, with aisles on four sides.**

An Island Booth is a booth exposed to aisles on all four sides. The entire cubic content may be used up to the maximum allowable height.

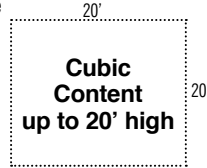

**Height**

Exhibit Fixtures and components will be permitted to a maximum height of 20'. At no point or height within the cubic content can footers, headers, lighting, truss, signage or any other display component exceed the invisible booth perimeter line.

**Hanging Signs & Graphics**

Signs and truss are limited only by ceiling height and fire regulations but must not exceed any portion of the booth perimeter. Truss may be used to hang or secure audio visual equipment, speakers, lights, monitors, and/or projectors. Equipment hanging from truss to be utilized as part of the demonstration of the products or services of the Exhibitor must meet all restrictions in regards to height, placement within the booth, and all exhibit construction guidelines of the booth. Hanging Signs and Graphics should be set back 10ft (3.05m) from adjacent booths and be directly over contracted space only. Approval for the use of Hanging Signs and Graphics, at any height, should be received from the exhibition organizer and the building (due to hanging points and weight) at least 60 days prior to installation. Variances may be issued at the exhibition management's discretion. Drawings should be available for inspection.

**Towers**

A Tower is a free-standing exhibit component separate from the main exhibit fixture. The height restriction is the same as that which applies to the appropriate exhibit space configuration being used. Towers in excess of 8ft (2.44m) should have drawings available for inspection. Fire and safety regulations in many facilities strictly govern the use of towers. A building permit or safety lines may be required.

**Lighting**

Lighting must be directed exclusively into the Exhibitor's booth, not in the aisles, nor in any part of the exhibit hall.

**Multi-Story Exhibit**

A Multi-story Exhibit is a booth where the display fixture includes two or more levels. In many cities, a Multi-storied Exhibit requires prior approval by the exhibit facility, and/or relevant local government agency, as well as show management because it is deemed to be a "structure" for building purposes. The city building department generally needs to issue a building permit based on an application and drawings prepared and submitted by a licensed architect or engineer. Exhibitors should obtain local building regulations early on to ensure that all time constraints are met. Exhibition organizers are prepared to assist exhibitors in this application process. For further questions please visit: [clarkcountynv.gov/depts/fire](http://clarkcountynv.gov/depts/fire)

**Issues Common to all Booth Types**

**Americans with Disabilities Act (ADA)**

All exhibiting companies are required to be in compliance with the Americans with Disabilities Act (ADA), and are encouraged to be sensitive, and as reasonably accommodating as possible, to attendees with disabilities. Information regarding ADA compliance is available from the U.S. Department of Justice ADA Information Line (800)514-0301, and from the ADA Website at: [ada.gov](http://ada.gov).

Some examples of how to design an exhibit for ADA compliance:

- Make exhibits wheelchair accessible by ramping raised exhibit flooring without extending a ramp into the aisle (Note: a standard wheelchair ramp should have a grade no steeper than 1:12. This means that for every inch of rise (change in height), there should be 12 inches of run (change in length))
- Ramp the entry or use hydraulic lifts for trailer exhibits
- Avoid double-padded plush carpet to ease mobility device navigation
- Provide the same attendee experience on both levels of a two-story exhibit
- Offer a signer or other auxiliary hearing-impaired apparatus for sound presentations or have a printed copy of the presentation available
- Run an audio presentation for people with sight problems
- Arrange touch screen displays at a height to accommodate a person sitting in a wheelchair

To avoid heavy fines by the U. S. Department of Justice, exhibitors must adhere to the ADA rules. Exhibits are not exempt from ADA compliance.

**Structural Integrity**

All exhibit displays should be designed and erected in a manner that will withstand normal contact or vibration caused by neighboring exhibitors, hall laborers, or installation/dismantling equipment, such as fork lifts. Displays should also be able to withstand moderate wind effects that may occur in the exhibit hall when freight doors are open. Refer to local building codes that regulate temporary structures. It is required that all 20ft by 20ft (6.10m by 6.10m) and over exhibits require a drawing, plans or renderings, preferably digital, be submitted to the show organizer. Exhibitors should ensure that any display fixtures such as tables, racks, or shelves are designed and installed properly to support the product or marketing materials to be displayed.

**Flammable and Toxic Materials**

All materials used in display construction or decorating should be made of fire retardant materials and be certified as flame retardant. Samples should also be available for testing. Materials that cannot be treated to meet the requirements should not be used. A flame-proofing certificate should be available for inspection. Exhibitors should be aware of local regulations regarding fire/safety and environment which must be adhered to. Exhibitors should dispose of any waste products they generate during the exhibition in accordance with guidelines established by the Environmental Protection Agency and the facility.

**Carpeting**

Carpeting is required in all types of exhibit spaces. Exceptions are made for bulk space utilized for trailer and large truck displays, but highly recommend the use of carpet around the trailer or truck.

**Drones**

Mandalay Bay does not permit drones in the exhibit hall or anywhere in the facility.

**Electrical**

Every exhibit facility has different electrical requirements. However, minimum guidelines are suggested:

All 110-volt wiring should be grounded three-wire.

- Wiring that touches the floor should be "SO" cord (minimum 14-gauge/three-wire) flatcord, which is insulated to qualify for "extra hard usage."
- Cord wiring above floor level can be "SJ" which is rated for "hard usage."
- Using zip cords, two-wire cords, latex cords, plastic cord, lamp cord, open clip sockets, and two-wire clamp-on fixtures is not recommended and is often prohibited. Cube taps should be prohibited.
- Power strips (multi-plug connectors) should be UL approved, with built-in over-load protectors.

**Lighting**

Exhibitors should adhere to the following suggested minimum guidelines when determining booth lighting:

- No lighting, fixtures, lighting trusses, or overhead lighting are allowed outside the boundaries of the exhibit space. Exhibitors intending to use hanging light systems should submit drawings to exhibition management for approval.
- Lighting, including gobos, should be directed to the inner confines of the booth space. Lighting should not project onto other exhibits or exhibition aisles.
- Lighting which is potentially harmful, such as lasers or ultraviolet lighting, should comply with facility rules and be approved in writing by exhibition management.
- Lighting that spins, rotates, pulsates, and other specialized lighting effects should be in good taste and not interfere with neighboring exhibitors or otherwise detract from the general atmosphere of the event.
- Currently, some convention facilities are not allowing quartz halogen lighting fixtures in exhibits due to potential fire hazards. Check with exhibition management.
- Reduced lighting for theater areas should be approved by the exhibition organizer, the utility provider, and the exhibit facility.
- LED lights can be very bright yet generally generate less heat

**Storage**

Fire regulations in most exhibit facilities prohibit storing product, literature, empty packing containers, or packing materials behind back drapes or under draped tables. In most cases, however, exhibitors may store a limited supply of literature or product appropriately within the booth area, so long as these items do not impede access to utility services, create a safety problem, or look unsightly.

*Display Guidelines excerpted from IAEE's 2014 Revised Guidelines for Display Rules and Regulations*

**Booth Demonstrations; Sound/Music**

**Demonstrations:**

As a matter of safety and courtesy to others, exhibitors, should conduct sales presentations and product demonstrations in a manner which assures all exhibitor personnel and attendees are within the contracted exhibit space and not encroaching on the aisle or neighboring exhibits. It is the responsibility of each exhibitor to arrange display, product presentation, audio visual presentations, and demonstration areas to ensure compliance.

Exhibitors should be aware of local regulations regarding fire/safety and environment which must be adhered to. Special caution should be taken when demonstrating machinery or equipment that has moving parts, cooking equipment with an open flame, or any product that is otherwise potentially dangerous.

Exhibitors should establish a minimum setback of 3ft (.91m) and/or install hazard barriers as necessary to prevent accidental injury to spectators. Additionally, demonstrations should only be conducted by qualified personnel.

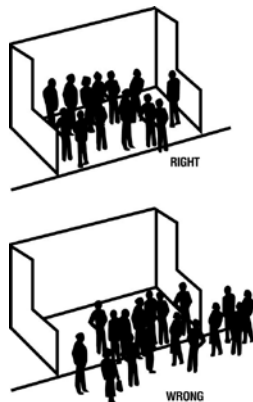

**Sound/Music/Scents**

In general, exhibitors may use sound equipment in their booths so long as the noise levels does not disrupt the activities of neighboring exhibitors. Speakers and other sound devices should be positioned so as to direct sound into the booth rather than into the aisle.

Rule of thumb: Sound and noise should not exceed 85 decibels when measured from the aisle immediately in front of a booth. (Refer to **OSHA at: [osha.gov](http://osha.gov)** for more information.)

Exhibitors should be aware that music played in their booths, whether live or recorded, may be subject to the laws governing the use of copyrighted compositions. ASCAP, BMI and SESAC are three authorized licensing organizations that collect copyright fees on behalf of composers and publishers of music.

Scents, odors, or fragrances radiating from a booth could affect persons with allergies or become overwhelming to neighboring exhibitors. Odors must be kept to a minimum and if determined objectionable, the Exhibitor will be required to turn off the device.

**Americans with Disabilities Act (ADA)**

All exhibiting companies are required to be in compliance with the Americans with Disabilities Act (ADA), and are encouraged to be sensitive, and as reasonably accommodating as possible, to attendees with disabilities. Information regarding ADA compliance is available from the U.S. Department of Justice ADA Information Line, (800) 514-0301, and from the ADA website at: [ada.gov](http://ada.gov). Note: Raised flooring on exhibits must be ADA compliant by providing proper ramping to accommodate wheelchairs, mobilized scooters, etc. regardless of the size of the exhibit booth. Ramping may not protrude into the aisle. There will be no exceptions or variances on this requirement; government fines may be imposed for non-compliance. Questions about ADA compliance may be directed to: 202-514-0301. The Exhibitor agrees to indemnify and hold harmless EXHIBITORLIVE for any claims arising out of or in connection with the Exhibitor's failure to make their display comply with the ADA.

**Aisles**

All aisle space belongs to the Exhibition. No exhibit, lighting, truss or advertising will be allowed to extend beyond the space assigned to the Exhibitor. Any demonstration or activity which results in the obstruction of aisles or prevents ready access to neighboring exhibitors' booths shall be suspended for any period specified by the Managing Directors.

**Balloons**

The use or display of helium filled balloons smaller than 36 inches is prohibited. Large helium-filled balloons, such as advertising balloons, may be used only if they are securely anchored to the exhibit and do not exceed the maximum height allowed for your booth. Note: prior approval must be obtained from the Managing Directors not less than 60 days before the opening date of the Show. Balloons are prohibited outside the exhibit hall; therefore it is recommended that balloons should not be distributed to attendees.

**Contests, Promotions, Models, Literature and Promotional Items Distribution**

The Exhibitor shall not permit exhibitions, raffles, donations or other promotional measures that require guests to be present at a specific location and time, and all unusual promotional plans must be approved by the Managing Directors no later than 60 days prior to the Show. Catalogs, souvenirs, literature, printed matter or any other items to be distributed at the Show are subject to approval by the Managing Directors. Any material not approved by the Managing Directors shall not be distributed. Uniformed attendants, models and other employees must be dressed in good taste and remain in spaces occupied by their employers, including robots. Any and all distribution of literature or other promotional items must be made from the Exhibitor's rented booth space. Furthermore, exhibiting trade publishers are prohibited from soliciting advertising in the Show aisles. They may distribute their own trade publications from their rented booth space, but no automatic distribution is to be made to the individual booths of exhibitors. Also see "Balloons."

**Damage To Property – Exhibit Hall**

Exhibitors are responsible for damage to uncrated or improperly packed shipments, concealed damage, loss or

theft of material after delivery to booth or before material is picked up for return movement. It is expressly understood that the Exhibitor will make no claim of any kind against the Managing Directors for any loss, damage or destruction of goods, nor for any damage of any nature to their business by reason of the failure to provide space for any exhibit or the removal of the exhibit.

**Electrical Regulations**

All electrical wiring on booths or display fixtures must meet applicable codes. In any power distribution system, power fluctuations and/or failures, although extremely uncommon, can occur. The Managing Directors, the Mandalay Bay Convention Center or the Official Electrical Service Contractor cannot be responsible for such occurrences, when they are out of the control of the Managing Directors, the Mandalay Bay Convention Center or the Official Electrical Service Contractor. It is standard practice for many persons exhibiting equipment sensitive to voltage fluctuations, power surges and/or outages, to utilize surge protectors, line conditioners and/or battery backup systems to guard against these events.

**Exhibit and Display Rules & Regulations**

All standard booth displays will be confined to a maximum height of 8'3" (2.5m) and all display fixtures over 4' (1.22m) in height and placed within 10 lineal feet of an adjoining exhibit must be confined to that area of the Exhibitor's space which is at least 5' (1.52m) from the aisle line. Island displays are permitted to a height of 20' (6.096m) when plans are submitted and approved by the Managing Directors at least 30 days prior to the opening of the Show. Send diagrams to:

Managing Directors  
EXHIBITORLIVE  
98 E. Chicago Avenue  
Westmont, IL 60559 USA  
Or email to: [EXHIBITORLIVE@heexpo.com](mailto:EXHIBITORLIVE@heexpo.com)

Hanging signs and truss have unlimited height, subject to ceiling height and sprinkler systems, in island booths (hanging signs are prohibited in linear booths). All open or unfinished sides are to be covered at exhibitor's expense so as not to appear unsightly. Linear exhibits shall not obstruct the view of adjoining exhibits nor be operated in any manner objectionable to other exhibitors. All lighting must be positioned within the perimeter of the exhibit and be arranged and operated so as not to be distracting to adjacent exhibits. The operation of videos, radios or other sound devices operated in an objectionable manner in the opinion of the Managing Directors shall be prohibited.

**Exhibitor Appointed Contractors (EAC's)**

See "Use of an Exhibitor Appointed Contractor"

**Food And Beverage Distribution**

Exhibitors shall not dispense or distribute any food, beverage or throwaway items not provided by the Mandalay Bay Convention Center without written approval of the Managing Directors and the Mandalay Bay Convention Center. Exhibitors are responsible for the prompt removal of bus trays from the Exhibit Hall. No trays are permitted in the public areas of the Show.

**Good Neighbor Policy**

Exhibitors are expected to minimize the noise level of sound amplifying, reproducing equipment. All unnecessary noise is prohibited.

The use of loudspeakers, sound projection equipment and any other sound augmenting devices in exhibit booths will be permitted only with the understanding that the volume is kept at a reasonable level and is not objectionable to surrounding exhibitors. Exhibitors planning to use "production numbers" are advised that prior approval must be obtained from Show Management (HEI).

Amplification equipment may be used only for recorded music leading to the introduction of product demonstrations, provided that the sound is not objectionable to other exhibitors. In all cases, Show Management's (hei) decision on any questionable noise level will be final and the Exhibitor agrees to abide by any such decision.

**Hanging Signs**

Exhibitors in island space booths (20x20 and larger) are allowed to suspend signs above their booth, subject to weight limitations and hanging points. Hanging signs are prohibited above linear booths (10x10, 10x20, etc.).

**Insurance**

EXHIBITORLIVE requires that each Exhibitor maintain general public liability insurance against claims for personal injury, death or property damage incident to, arising out of or in any way connected with the Exhibitor's participation in the exhibition, in an amount of not less than one million dollars (\$1,000,000) for personal injury, death or property damage in any one occurrence. Such insurance maintained by the Exhibitor must be issued by an insurance company reasonably acceptable with an A.M. Best rating A- or higher to the Managing Directors and should include coverage of the indemnification obligations of the Exhibitor under these rules and regulations, and shall name EXHIBITORLIVE, the producers, Exhibitor Media Group, the Managing Directors, Hall-Erickson, Inc. (hei), the General Contractor, Freeman and the Mandalay Bay Resort & Casino as additional insureds on the general liability policy. Each Exhibitor is required to indemnify and hold harmless the Mandalay Bay Resort & Casino from all liability (damage or accident) which might ensue from any cause resulting or connected with transportation, placing, removal or display of exhibits. Each Exhibitor is required to carry workers compensation coverage protecting employees in accordance with the laws of the State of Nevada. Each Exhibitor acknowledges that it is responsible for obtaining, for its protection and entirely at its expense, such property insurance for its exhibit and display materials as the Exhibitor deems appropriate. The Exhibitor understands that neither EXHIBITORLIVE, the producers, Exhibitor Media Group, the Managing Directors, Hall-Erickson, Inc. (hei), the General Contractor, Freeman nor the Mandalay Bay Resort & Casino maintain insurance covering the Exhibitor's property and it is the sole responsibility of the Exhibitor to obtain such insurance. Any policy providing such property insurance must contain an express waiver by the Exhibitor's insurance company of any right of subrogation to any claims against EXHIBITORLIVE, the producers, Exhibitor Media Group, the Managing Directors, Hall-Erickson, Inc. (hei), the General Contractor, Freeman and the Mandalay Bay Resort & Casino.



**Labor Regulations**

In order to conform to union contract rules and regulations, all exhibitors must use qualified union personnel to install and dismantle exhibits and to handle material in and out of the Show. The handling and placing or setting out of merchandise that is to be displayed does not require union labor and may be done by the Exhibitor with full time personnel. Exhibitors must carry company identification to prove full-time employment. Full-time employees of the Exhibitor, age 18 and over, may set up and take down their own exhibits, with the use of hand tools, but forklifts or any other heavy equipment required, must be retained through and operated by the general service contractor. For a safe and efficient move in by all parties involved, the dock area will be under control of the Official Service Contractor. No exhibitors will be allowed to hand carry items through this area. Hotel bellmen or Business Center personnel will not be permitted in the exhibit hall; bell carts are not allowed in the registration area or on the show floor. See "Shipments to Mandalay Bay" for more information about shipping and hand-carry items.

**Lighting**

Exhibitors should adhere to the following suggested minimum guidelines when determining booth lighting:

- No lighting, including Gobo lights, fixtures, lighting trusses or overhead lighting are allowed to be installed outside the boundaries of the exhibit space. Exhibitors intending to use hanging light systems should submit drawings to the Managing Directors for approval. Truss must not exceed the booth lines.
- Lighting should be directed to the inner confines of the booth space. Lighting should not project onto other exhibits or show aisles.
- Lighting which is potentially harmful, such as lasers or ultraviolet lighting, should comply with facility rules and be approved in writing by the Managing Directors.
- Lighting that spins, rotates, pulsates and other specialized lighting effects should be in good taste and not interfere with neighboring exhibitors or otherwise detract from the general atmosphere of the event.
- Ceiling lights over an aisle or another exhibitor's booth may not be disconnected.
- Gobo lights, etc. must be focused within the confine's of the Exhibitor's booth.

**Movement of Exhibit Materials**

Materials which can be hand-carried by an individual (such as portable exhibits, literature and sample products) may be brought through the entrance to the Show. However, hand carts, dollies, flatbeds or luggage carts may not be used by exhibitors, business center personnel, or hotel bellmen to deliver materials to an Exhibitor's booth. Movement of material requiring a cart is under the jurisdiction of the General Service Contractor and must come over the dock area. For information on delivering material by private automobile or van, contact our official contractor or go to Exhibitor Service Center.

**Multi-Story Exhibit Regulations and/or Displays over 12 Ft. in Height**

All multi-story exhibits, regardless of whether people will occupy the upper area or not, and all exhibit fixtures and components exceeding 12'0" (3.66m) in height must have drawings available for inspection by the Managing Directors, the Official Contractor and government authority during the time the exhibit is being erected, exhibited and dismantled at the Show site that include a signature or stamp of a reviewing structural engineer indicating that the structure design is properly engineered for its proposed use, and a signature of an authorized official of the exhibit building company indicating that the structure is built in compliance with the details and specifications set forth on the drawings. Signs must also be posted indicating the maximum number of people the structure will accommodate.

Booths that obstruct exits will have to be relocated.

If covered booths exceed 1,000 square feet, they need interior automatic sprinkler protection if they will be in place for more than seven show days or if they contain vehicles, open flame, or hot works. Provide a separate sprinkler installation permit application for covered that require fire sprinklers.

The upper level of multi-level exhibit booths exceeding 300 square feet shall have not less than two remote means of egress.

Booth construction is to be made of materials complying with the Clark County Fire Code as follows:

- Noncombustible materials
- Wood exceeding ¼ inch nominal thickness
- Wood that is pressure-treated, fire-retardant wood meeting the requirements of NFPA 703, Standard for Fire-Retardant Coatings for Building Materials
- Flame-retardant material complying with NFPA 701, Standard Methods of Fire Tests for Flame Propagation of Textiles and Films
- Textile wall coverings, such as carpeting and similar products used in wall or ceiling finishes complying with Section 803.5.2 of the IFC
- Plastics limited to a Class A flame spread index
- Foamed plastics and materials containing foamed plastics complying with Section 807.4.2.1 of the IFC
- Cardboard, honeycombed paper, and other combustible materials having a heat release rate for any single fuel package that does not exceed 150 kW where tested in accordance with UL 1975, Standard for the fire Tests for Foamed Plastics Used of Decorative Purposes

**Fire Suppression Features:**

1. Fire extinguishers originally placed by the building owner as required and approved by the FPB at the time of original certificate of occupancy are acceptable.
2. Additional fire extinguishers may be required if the travel distance to a fire extinguisher exceeds 75-feet or if there as Special Hazards. Cooking and hot-works like welding are examples of Special Hazards.
3. Fire extinguishers and fire hose cabinets shall not be obstructed. Keep them clear of displays, booths, drape, signs, decorations and the like.

**Photography and Videotaping**

Photography and videotaping are discouraged. Photographs and video of exhibitor booths may be taken with the express consent of the individual exhibitors. Individuals violating this rule will be removed from the Show floor and their film or camera will be confiscated. Properly registered press representatives will be photographing the Show and individual exhibits.

**Positioning Equipment In Relation To Aisle**

To ensure the safety of all EXHIBITORLIVE participants, every attempt should be made to position exhibit fixtures so that no portion is closer than 12 inches (30.48cm) from the aisle.

**Products and Services To Be Exhibited**

No Exhibitor shall exhibit, or permit to be exhibited in the space allotted to him any goods or services other than those specified on the application when approved by EXHIBITORLIVE, nor shall the Exhibitor permit to be exhibited therein, displays, literature or advertising of any sort bearing any name or form of advertisement other than his own. Retail sales are not permitted except by separate contractual agreement.

**Responsibility for Security**

The responsibility of security for each exhibit is that of the Exhibitor. EXHIBITORLIVE will provide crowd-control admittance security to the exhibit hall. Neither EXHIBITORLIVE, the producers, Exhibitor Media Group, the Managing Directors Hall-Erickson, Inc. (hei), the General Contractor Freeman nor the Mandalay Bay Resort & Casino will be responsible for the safety of exhibits against theft, fire, loss, accident or damage from any other cause, or for accidents to exhibitors, their employees or any other person in or about said premises, except where caused by sole negligence or misconduct on the part of Exhibitor Media Group, the Managing Directors (hei), the Mandalay Bay Resort & Casino or the General Contractor Freeman. \* Exhibitors are encouraged to budget and make security arrangements for sensitive or valuable items.

**Shipments to Mandalay Bay:** All shipments should be consigned to your booth through Freeman, the general contractor. **Do not send your shipment to the business center at Mandalay Bay unless you can pick it up yourself and hand carry the item to your booth.**

For safety reasons, Business Center Staff and/or hotel bellman will not be allowed on the exhibit floor. Any boxes or items that can not be hand carried by your own staff will be delivered by Freeman, and will be subject to additional delivery (drayage) charges.

**Signs**

All signs must be located within the boundaries of the assigned booth space and hung no higher than the height limitation of the space assigned. Signs may not be attached to walls outside an Exhibitor's space, nor may they be hung from the ceiling except over the Exhibitor's assigned space where eligible. Any signage or promotional language on equipment must be part of the original equipment.

**Smoking**

Smoking is strictly prohibited within the Mandalay Bay Convention Center.

**Social Functions**

Exhibitors may conduct social functions in public areas of the Mandalay Bay Convention Center which do not conflict with scheduled programs or activities of the EXHIBITORLIVE. No exhibitor shall conduct or sponsor during published Show hours any banquet, breakfast, luncheon, party or other function for attendees, or for those who have been invited to attend the EXHIBITORLIVE, without the written approval of the Managing Directors.

**Sound Amplifying, Reproducing Equipment**

In general, exhibitors may use sound equipment in their booths so long as the noise level does not disrupt the activities of neighboring exhibitors. Exhibitors operating sound reproducing or sound amplifying equipment are required to operate in such a manner that a maximum 85db reading on the "A" scale of a sound level meter may be read at the aisle(s) space adjacent to their booth or measured at a neighboring booth in an area bordering that of the sound equipment user.

The Managing Directors shall be the sole arbiter of acceptability of sound levels whether a sound meter is used or not, and may require reduction of sound level or elimination of sound reproducing devices in those instances where in violation of these standards or otherwise are objectionable. Exhibitors using sound amplification equipment are requested to have the equipment comply with Section 1910-95, Occupational Noise Exposure, page 22157 of the Department of Labor Occupational Safety and Health Administration rules and regulations pertaining to a standard eight (8) hour operating shift.

**Space Assignment Policy**

Current and past exhibitors who mail in their contract or bring it to the Show Management Office at EXHIBITORLIVE, before Monday, February 26, 2018 are eligible for inclusion in the first round of space assignments for EXHIBITORLIVE. After Wednesday, February 28, 2018, current and past exhibitors will be assigned space on a first-come, first-served basis for the remaining available exhibit space.

The combined total of exhibiting history points, sponsorship and advertising points, will determine the ranking order of space assignments. You Get One (1) Point for each year you've exhibited (Original charter exhibitors (1989) get one Bonus point). Receive One (1) Point for every \$1,000 spent on exhibit space (no fractional points awarded; must be fully paid by January 1, 2018). Earn Two (2) Points for every \$1,000 spent on EXHIBITOR Advertising and Sponsorships (prior calendar year – advertising with EXHIBITOR magazine, Find It-Marketplace or ExhibitorOnline.com; sponsorship of EXHIBITORLIVE, EXHIBITORFastTrak or EXHIBITOR eTrak). Contracts will be date and time-stamped. In the event two exhibitors have equal points and both request the same location, this information will be considered in the ranking process and/or a drawing will be held. A twenty five percent (25%) deposit will be due within thirty days of space assignment. Exhibitors

who participated in past EXHIBITOR Shows have earned seniority points. These points will be applied to the space assignment process and a value of five (5) points will be assigned for each seniority point.

**Space Usage and Allocation**

The space applied for is to be used solely for the Exhibitor whose name appears on the application, and it is agreed that the applicant will not assign, or apportion the whole or any part of the space allotted. Furthermore, the Exhibitor agrees that the Managing Director has the sole authority over the assignment of exhibit space, and may be required to change the Exhibitors confirmed exhibit space in order to accommodate the needs of the Show. In the event the Exhibitor's booth number is changed, the Exhibitor will be notified promptly by the Managing Director.

**Sub-Leasing**

Exhibitor may not sublet their space, nor any part thereof, nor exhibit, offer for sale, give as premium, or advertise articles not manufactured or sold in their name, except where such articles are required for the proper demonstration or operation of Exhibitor's display, in which case identification of such articles shall be limited to the regular nameplate, imprint, or other identification which in standard practice appears normally on them. Exhibitor may not permit these non-exhibiting companies representatives in their booth. Rulings of the Managing Directors shall in all instances be final with regard to use of any exhibit space.

**Union Labor and Work Agreements**

The Exhibitor hereby agrees to abide by all agreements made between the unions, Freeman, EXHIBITORLIVE, its agents and the Mandalay Bay Convention Center pertaining to the use of union labor while in the Mandalay Bay Convention Center.

**Use of an Exhibitor Appointed Contractor (EAC)**

The Exhibitor hereby agrees not to contract for, nor to use, any services in connection with its exhibit in the Mandalay Bay Convention Center except such as shall be made available or approved by the Managing Directors not less than 30 days before the opening date of the Show. The Exhibitor shall supply to the Managing Directors the names of any persons or organizations other than those designated as Official Contractors in the Exhibitor Guide & Service Manual, who are proposed for the performance of any service for the Exhibitor. The Managing Directors will promptly notify Exhibitor of its approval or disapproval of such selections. Use of any non-official service contractor is also subject to those designated contractors providing proof of insurance to the Managing Directors 30 days prior to the opening of the Show. The certificate should name EXHIBITORLIVE (the show), Exhibitor Media Group (the producers), Hall-Erickson, Inc. (the Managing Directors), Freeman (the General Contractor), and the Mandalay Bay Resort & Casino (the venue) as additional insureds. Please refer to sample certificate in the exhibitor manual for coverage & limits required. EAC's include installation and dismantling contractors, florists, photographers, furniture and carpet suppliers and any other supplier or contractor used by the Exhibitor that is not the Show's official contractor. Certain services are considered exclusive contractors of Mandalay Bay and exhibitors

are required to use their service for: Booth Catering, Booth Cleaning, Electrical, Internet, Plumbing, Rigging, Telephones, Video Signal Distribution.

Names of the EAC's must be submitted to the Managing Directors by exhibitors on the form contained in the Exhibitor Guide & Service Manual. Each EAC must wear proper credentials issued by the Show, and agree to abide by the Show rules and regulations. It is the responsibility of the Exhibitor to oversee compliance of these rules with their EAC's.

**Vehicle Displays**

Any vehicle or other apparatus which has a fuel tank and is part of a display is required to be equipped with a locking gas cap (or taped gas cap) and contain no more than 1/4 tank of fuel. You must disconnect the battery cables of your vehicle once it is positioned and it cannot be operated. Ignition keys and propane tanks must be removed. The vehicle must be equipped with its own fire extinguisher and visqueen must be placed underneath the vehicle.

**Trade Show/Exhibits**

Storage of any kind behind back drapes, display walls or inside the display areas is not allowed. All cartons, crates, containers, packing materials etc., necessary for repackaging, must be marked with an "Empty" sticker.

All packing containers, wrapping materials and display materials must be removed from behind booths and placed in storage.

For double-deck booth: If the booth is over 1000 sq.ft., you are required to have a licensed sprinkler contractor from the state of Nevada to pull a sprinkler permit. If your booth is under 1000 sq.ft., you do not need a permit.

All booths with covered surfaces greater than 1,000 sq. ft. are required to contain internal automatic fire sprinklers.

Fire sprinkler systems must be installed by a Nevada state licensed fire sprinkler contractor. When a multi-level enclosed exhibit is used in a show, a self-contained automatic fire extinguishing system may be required upon review by the Clark County Fire Department (CCFD). Booths with covered surfaces greater than 1,000 sq. ft. and 4,000 sq.ft. multi-level booths must submit an [Application for Permit](#) and a copy of their exhibit booth plans to:

Clark County Fire Department  
Fire Prevention Bureau  
Plans Check Division  
575 East Flamingo Road  
Las Vegas, NV 89119  
TEL: 702-455-7316  
[permits@co.clark.nv.us](mailto:permits@co.clark.nv.us).

All manufactured homes must have two (2) means of egress. All multi-level booths must be stamped by a certified structural engineer and must have two (2) means of egress from upper levels. All fully enclosed booths with enclosed rooms must have at least two (2) exits if greater than 1,000 sq.ft., or if more than 10 persons will occupy the second story; the exits must lead directly to the aisle. Signage should be placed on the staircase indicating the occupancy level on the second floor. These booths must possess a smoke detector and fire extinguisher for each enclosed area. The CCFD may require additional equipment.

If any exhibiting booths have multiple levels or room(s) with enclosures, visible notification must appear on the stairway(s) or outside the room. This notice must state the maximum occupancy permissible or total weight load allowable on the second story at one time. If the second story occupancy level allows more than ten (10) people at one time, a second stairway must be present.

All materials used in the construction of the booth and all decorative materials (drapery, table coverings, banners, foam board, signs, set pieces, etc.) within exhibitor booths and those used for special events must be non-combustible or made flame retardant.

Foam plastic elements greater than 1/4 inch thickness shall not be permitted. Fire resistant foam board signage, not greater than 1/2 inch thickness is acceptable.

You must maintain copies of flame certificates on premises as the CCFD can require verification at any time. Utilizing cardboard boxes as parts of exhibits or displays is not permissible.

Booth construction shall be substantial and fixed in position in a specified area for the duration of the show. Aisles and exits as designated on approved show plans shall be kept clean, clear and free of obstructions. Easels, signs, etc. shall not be placed beyond the booth area into aisles. Exhibitors must keep their booths and displays within the designated perimeters. Any violators will be made to move their exhibits.

Literature on display shall be limited to reasonable quantities. Reserved supplies shall be kept in closed containers and stored in a neat and compact manner.

Booths shall be cleaned of combustible materials daily.

Designated "No Freight" aisles are required. These aisles must be kept clear at all times during the move in and move out of trade shows.

Compressed gas cylinders are prohibited unless prior approval is obtained from the Fire Marshal. Approved cylinders must be stored in an upright position. Helium canisters are permitted, but only in a secured, upright position. Helium canisters must be removed during non-show hours.

Non-display vehicles cannot remain on the exhibit floor. Attendees will not have access until all non-display vehicles exit the show floor.

The painting of signs, displays or other objects are strictly prohibited inside of the facility or on Mandalay Bay Convention Center grounds. The CCFD may exercise the right to assign a fire detail to the premises, at your cost.

**Balloons**

- The use of helium balloons smaller than 36 inches in diameter is not allowed.
- Large helium-filled balloons, such as advertising balloons, may be used only if they are securely anchored to the exhibit. No helium balloons or blimps may be flown inside the building.
- Mylar balloons are not allowed anywhere on property.
- Helium gas cylinders for refilling must be secured in an upright position on safety stands with the regulators and gauges protected from damage. No overnight storage of helium or compressed air cylinders in the building is allowed.
- Balloons cannot be released out of doors due to airport flight patterns in the area. A cleaning fee will apply should the balloons be left on property after the event.

**Concrete/Asphalt Anchoring**

Drilling and anchoring in concrete is not allowed. Drilling in any other surface inside or outside must be approved in advance by your designated convention services manager at Mandalay Bay.

**Cooking Demos and Food Product Displays**

\*\*Please note the following information and codes could change by the Clark County Fire Department without

prior notice. All information is subject to the Mandalay Bay Convention Center approval as well as the CCFD prior to production or installation on property.\*\* For further clarification, please contact your CM.

Exhibitors are responsible for complying with all Southern Nevada Health Department regulations. Following are the regulation numbers that pertain to exhibition cooking: 96.01.0045 and 96.01.0039 and 96.02.0000 and 96.09.0000 and 96.09.0100 and 96.09.0200. For more detailed information please refer to the Southern Nevada Health Department website: [southernnevadahealthdistrict.org](http://southernnevadahealthdistrict.org) or contact them at 702-759-1000. Cooking and warming of food or beverage is prohibited unless reviewed by the Clark County Fire Department prior to the event and meet requirements of the Uniform Fire Code.

**Electrical/Plumbing/Gas/Compressed Air Water/Drains**

All electrical, plumbing, and compressed air services are provided exclusively by Mandalay Bay's outside contractor for all events including trade shows, general sessions, productions, etc. Outside electrical plumbing, gas and compressed air providers will not be permitted to work within the property. Mandalay Bay Convention Center has jurisdiction over the installation, operations; maintenance, and repair of all portable electrical wiring and electrical equipment at trade shows, conventions and events.

**Emergency Equipment**

Mandalay Bay Resort is equipped with alarm and sprinkler systems. Fire extinguishers and other emergency equipment are strategically located in all areas of the building. The Mandalay Bay Convention Center Security Office monitors all building emergency systems throughout the facility. It is imperative that all fire hose cabinets, strobes, and fire extinguishers be kept clear, accessible, and free of obstructions at all times. The fire hose cabinets, strobes, and fire extinguishers are permanent fixtures of the facility and cannot be moved. Fire strobes are located 12 feet up on each side of every column. These strobes cannot be covered or obstructed at any time.

**Emergency/Evacuation Procedures**

Mandalay Bay Resort is equipped with sophisticated electronic fire detection and alarm systems which are designed to notify our Fire Command Center the location of any incident that triggers a detector or activates the sprinkler system. Once an alarm has been initiated, members of Mandalay Bay's trained Security & Engineering staff immediately respond to the location of the alarm, determine the source, assess the situation and report back to the Fire Command Center with their evaluation. Evacuation is not automatic and is only ordered when warranted.

In the unlikely event of fire, our facilities are equipped with state-of-the-art fire suppression systems to control and extinguish fires of major consequence. In addition, portable fire extinguishers have been strategically placed throughout the property to allow for extinguishing fires in their incipient stage, before they endanger our patrons and employees.

**Floor Load Limits**

The floor load limits in the exhibition halls are 350 pounds per square foot, live load. All ballroom and meeting room floor load limits are 150 pounds per square foot, live load. Any exhibit exceeding this limit will require special handling to distribute the load.

**Food Samples**

All exhibitors approved by Mandalay Bay to serve open (unpackaged) food in a trade show booth must apply for a Food Permit by mail or in person at the Southern Nevada Health District. You are responsible for complying with applicable Southern Nevada Health District regulations, which include, but are not limited to:

- All potentially hazardous foods (meats, dairy products, poultry, melons, etc.) must be maintained at proper temperatures: 41 degrees F. or colder or 135 degrees F. or hotter.
- Poultry products must be cooked to 165 degrees F. Stem thermometers must be available to monitor food temperature.
- Adequate refrigeration must be available for proper food storage.
- Samples must be protected from contamination by sneeze guards, domes, or covers.
- Suitable utensils or individual portions must be provided.
- Single-service gloves or suitable utensils must be provided for handling of all ready to eat food.
- Handwashing must be available with 110 degree water. Exhibitors handling food must wash their hands for 20 seconds upon entering their work station. Sanitizer must be provided at each booth, and the Exhibitor should have knowledge of what sanitizer they are using. Suggested sanitizer is QUAT (150-400 ppm) or Chlorine (50-100 ppm). Test strips should be available to check the levels of the sanitizer.
- No smoking or eating is permitted in any booth preparing or serving food.
- A fire extinguisher must be provided in any area using canned heat, gas or fire.
- Adequate extension cords must be available and stored to prevent electrical shock or a tripping hazard.
- All beverages must have a lid.

Please address further questions to:  
 SOUTHERN NEVADA HEALTH DISTRICT  
 Environmental Health Division  
 625 Shadow Lane  
 Las Vegas, NV 89127  
 (702) 759-0588

Website:  
 southernnevadahealthdistrict.org  
 Email: environmentalhealth@snhdmail.org

Mandalay Bay Convention Center guidelines for the service of prepared food are as follows:

- Samples are limited to manufactured, processed or distributed products only.
- Food samples are limited to one (1) ounce.
- Beverage samples are limited to two (2) ounces.
- Items used as traffic promoters must be purchased through Mandalay Bay.
- Exhibitor Services department must approve all samples.
- Each exhibitor intending to serve samples must advise Exhibitor Services for approval and instructions.
- Corkage and gratuity fees may apply.

**General Facility**

All fire exits and the illuminated exit sign above each must be clearly visible. Exit doors, exit signs, fire alarm, fire hose cabinets and fire extinguisher locations cannot be concealed or obstructed. According to the Nevada Clean Indoor Act, there is no smoking permitted in the facility with the exception of the main casino and designated guest rooms.

Open flame devices of any kind are prohibited in all assembly areas, unless pre-approved by the Clark County Fire Department; they must meet requirements of the Uniform Fire Code and permit requirements of the Clark County Fire Department.

The Clark County Fire Department requires special permits for the following:

- Display or operation of any heater, barbecue, heat-producing device, open flame, candle, lamp, lantern, torch, etc.
- Display or operation of any electrical, mechanical or chemical device that the fire department deems hazardous.
- Use or storage of flammable liquids, compressed gas or dangerous chemicals.
- Vehicle Displays

**Halogen Lighting**

This policy covers restrictions on stem mounted halogen lighting provided by display contractors and exhibitors for the temporary lighting of exhibit booths. The use of any stem mounted halogen or other fixtures employing a non-shielded halogen bulb is not allowed. The maximum wattage is 75 watts.

In addition, conventional track lighting systems that use any of the approved types of halogen bulbs and that are securely mounted to stable exhibit structures will continue to be allowed.

**Approved Halogen Bulbs**

- MR 11/16 Covered-low voltage
- MR 16 Covered-line voltage
- PAR 14,16,20,30 and 48

**Disapproved Halogen Bulbs**

- MR 11/16 Uncovered
- Line Voltage
- Low Voltage-Bi-Pin

**Hazardous Materials**

All parties affiliated with your event are prohibited from possessing, storing, or bringing onto the property materials that constitute hazardous materials (as defined by federal, state and local law) unless the hazardous materials are possessed and used in compliance with all federal, state and local laws. You will indemnify us for any possession, storage, transportation and use of such hazardous material for any reason whatsoever. All outside contractors/vendors are required to have a material safety data sheet (MSDS) on any hazardous chemical that they bring into the facility, so that appropriate action can be taken to inform and protect our employees.

**Production/AV**

Electrical panels must have thirty (30") inch clearances

in front. All other electrical equipment (cords, plugs, etc.) must be in accordance with the Uniform Fire Code and the National Electrical Code, as well as local codes. Any use of two wire extension cords is prohibited. Multiple outlets and electric cords must be grounded and must not exceed their listed amperage rating. All temporary electric wiring must be accessible and free from debris and storage materials.

A certified fire watch is required the entire time special effects are utilized which require the Mandalay Bay Convention Center to manually control any sections of our fire safety system. Special effects would be, but are not limited to, fog machines, pyrotechnics and cooking. A schedule of the times that Mandalay Bay Convention Center is to manually control our fire safety system is required 30 days prior to the event.

Displays involving flammable or combustible liquids or materials and pyrotechnic displays must be demonstrated to the CCFD for issuance permit.

Exit doors, exit signs, fire alarm, fire hose cabinets, strobes, and fire extinguisher locations may not be concealed or obstructed and must be maintained in proper working condition.

Projection booths must be ventilated at the ceiling and provided with an approved smoke detector. Storage is not allowed in these areas.

**Backstage and rear screen projection guidelines:**

- No storage boxes, musical cases, etc. may be stored in service hallways.
- Hiperthane cable protectors must be used to ramp all cable 1" in diameter or greater.
- Ramp all cable leaving a function room to an outside area.
- All wires less than 1" in diameter must be taped down with gaffer's tape.
- If exiting is covered by stage masking, there must be a clear path from masking to exit and illuminated exit sign located on masking.
- Any fire extinguishers or fire hose cabinets located backstage must be clear and easily accessible.

**Vehicles On Premise**

The Clark County Fire Department 2005 UNIFORM FIRE CODE states that all procedures must be in accordance with section 2505 when pertaining to general liquid-fueled and gas fueled vehicles and equipment for display, competition and/or demonstration.

Automobiles or other fuel powered vehicles of any nature must adhere to the following guidelines:

- Fuel in the tank shall not exceed 1/4 of the tank capacity
- Vehicles shall not be fueled or refueled within the building
- Batteries to be removed or disconnected
- Locking gas caps or caps sealed with tape ignition keys removed
- Propane tanks to be removed
- Visqueen or other protective covering approved by the Mandalay Bay Convention Center placed underneath vehicle
- At least 30" clear access or aisles must be maintained around the vehicle



The Managing Directors require all exhibitors to comply with their responsibilities to the physically challenged. Exhibits are considered "public accommodations" and are subject to the requirements of the Americans with Disabilities Act (ADA). The following are some suggestions for accommodating attendees to EXHIBITORLIVE who are physically, visually or hearing impaired. Non-compliant exhibitors will be asked to make alterations to remove architectural barriers wherever it is readily achievable and technically feasible, and where removal of such barriers does not place an undue financial burden on the company. For more information contact the U.S. Department of Justice ADA Information Line, (800) 514-0301, or the ADA website at: [ada.gov](http://ada.gov)

#### **Hearing Impaired**

- Provide listening systems.
- Avoid high noise levels as this is particularly frustrating to people with limited hearing.
- Live demonstrations should have printed materials to complement oral presentations.
- Reserve a front row demonstration seat for those with hearing problems.

#### **Visually Impaired**

- Convert text into Braille.
- Avoid protruding objects that a visually impaired person could walk into.
- Avoid raised platforms.
- For long meetings with visually impaired customers accompanied by a seeing-eye dog, have water and/or dog food available.
- Have large print literature available, or put materials on disk for use on computers.
- Provide a sound read back for people with sight problems, or other audio presentation.
- Avoid sharp corners.
- Avoid carpet piling, as well as wires and "bumps".
- If a presentation is held on the second deck, offer a videotaped version in a lower lounge.

#### **Physically Impaired**

- Entrance width to the booth should be wide enough to accommodate a wheelchair.
- Avoid raised platforms or provide proper ramping.
- Booth catering should be served at a height to accommodate a person sitting in a wheelchair.
- Touch screen displays should be reachable by persons in wheelchairs.
- Avoid sharp corners at eye level for wheelchair and motor skill-impaired attendees.
- Avoid carpet piling, as well as wires and "bumps".
- If a presentation is held on a second deck, offer a videotaped version in a lower lounge.
- Counters and displays should be lowered to 34 inches.

#### **Staff Training**

- Train a member of staff in signing for hearing-impaired visitors.
- Speak directly at a person with a hearing impairment. Don't look down.
- Let him or her see you speak. Don't raise your voice unless asked.
- When speaking with a person in a wheelchair sit down so you are at the same eye level.
- Talk directly to a person with a disability. Don't talk to him or her through a companion.
- Let disabled people give you instructions for accommodating their needs.
- Booth staffers should be prepared to describe what the booth contains and what a product demo is doing.

Sources: EXHIBITOR, Expo Magazine, International Association for Exhibitions & Events

EXHIBITOR MAGAZINE PRESENTS

# **EXHIBITOR***LIVE*

THE PROFESSIONAL DEVELOPMENT CONFERENCE FOR  
TRADE SHOW AND CORPORATE EVENT MARKETING

## **QUESTIONS?**

Contact

Hall-Erickson, Inc.

Managing Directors

98 E. Chicago Ave.

Westmont, IL 60559 USA

Tel: 800.752.6312;

or 630.434.7779

Fax: 630.434.1216

Email: [exhibitorlive@heiexpo.com](mailto:exhibitorlive@heiexpo.com)